

PAVO™ -DIAL-DMX 24V CONTROLLER

Features

- Single lamp RGB LED color-changing lighting system controller.
- 7 mode settings for single colors and color-changing patterns.
- Four positions: Function, Speed, Brightness and Contrast for easy operation.
- Three-channel DMX output: Ch. 1 (R), Ch. 2 (B), Ch. 3 (G).
- Ideal controller for up to 15 meters (max.) of the STARSTREAM-24-RGB (expandable with the SS-Coupler™).



Electrical Specifications

Parameter	Value
Electronic Specifications	
Driver Capacity	(R+G+B) 4A, 100W@24V
Input Voltage	21 ~ 28VDC
Driver Out	R/G/B, VDD
DMX Output	Standard DMX-512, 3 channels, ID = 1, 2, 3 (R/G/B)
Terminal block	3.81mm pitch, screw type (7A)
Interface Specifications	
Functions	R/G/B/White/Fade 1/Fade 2/Random Flash
Input Interface	Speed/Brightness/Contrast: 32 levels
Memory	Last mode is set to memory after the controller is turned OFF for 5 seconds.
Environment Specifications	
Operation Temperature	0~50°C
Storage Temperature	-20~60°C
Humidity	10~90%
Dimensions	120 x 70 x 34mm
Weight	95 g

SS- Coupler™

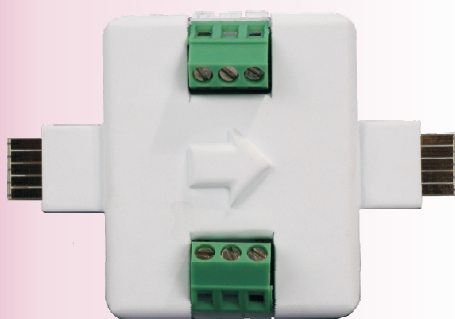

Connect additional lengths of up to 12 meters of the STARSTREAM-24-RGB with the SS-Coupler™. (A separate power supply must be connected to the SS-Coupler™ to provide power.)

Ver: 20081212

Taiwan Operations: Color Stars, Inc.

10F, No. 566 Jung Jeng Rd. Sindian City
Taipei County 231, Taiwan, R.O.C.
Tel: +886-2-8667-6600 Fax: +886-2-8667-1400
Email: sales@colorstars.com Website: www.colorstars.com



Headquarters: ColorStars Group

300 Center Ave., Suite 202
Bay City, MI 48708 USA
Tel: 989-509-5924 Fax: 989-509-5924
Email: sales@colorstars.com Website: www.colorstars.com

PAVO™ -DIAL-DMX CONTROLLER

A. Connection diagram for an RGB LED fixture.

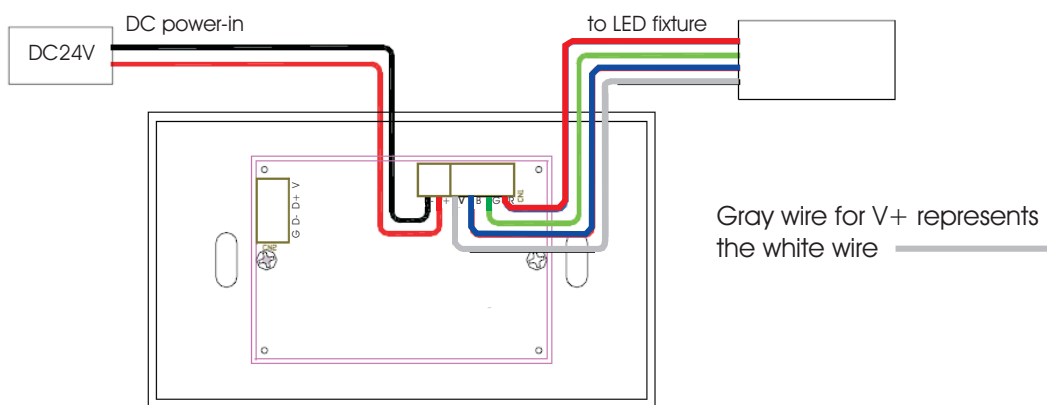

B. Connection diagram for a DMX LED Fixture

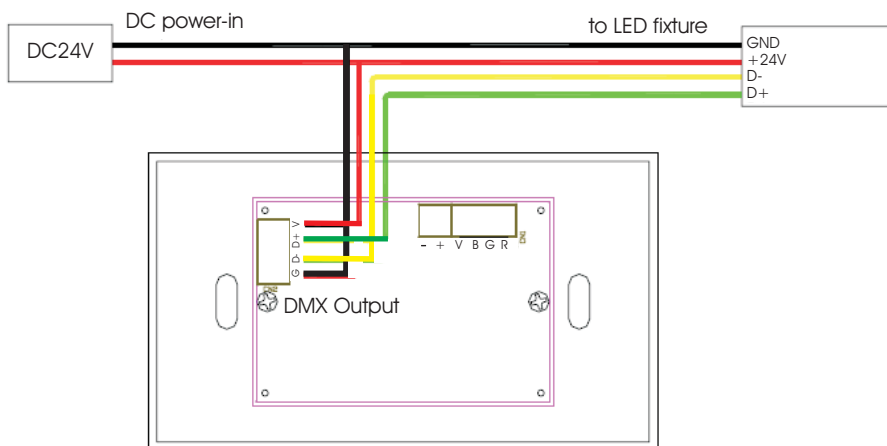

Taiwan Operations:
Color Stars, Inc.
10F, No. 566 Jung Jeng Rd. Sindian City
Taipei County 231, Taiwan, R.O.C.
Tel: +886-2-8667-6600 Fax: +886-2-8667-1400
Email: sales@colorstars.com Website: www.colorstars.com

Headquarters:
ColorStars Group
300 Center Ave., Suite 202
Bay City, MI 48708 USA
Tel: 989-509-5924 Fax: 989-509-5924
Email: sales@colorstars.com Website: www.colorstars.com